



## PowerDelta

Compact and powerful robot for micro-assembly



# PowerDelta

Compact and powerful robot for micro-assembly

The PowerDelta is the ideal solution for fast displacements, force fitting or assembly of small components. Its speed and precision allows up to 2 pick-and-place movements in a second. The PowerDelta can provide a vertical force of 50 N and allows to force fit parts that need to be joined.

## TECHNICAL DATA

### PowerDelta 250

Degrees of freedom:	3 (x,y,z)
Multi-directional repeatability:	$\pm 10 \mu\text{m}$ ( $3\sigma$ )
Workspace:	$\emptyset D$ : 250 mm h1: 60 mm h2: 190 mm
Cycle-time: (path: 20 x 200 x 20 mm)	500 g: 0.50 s
Force in vertical direction (z):	50 N

## CONTROLLER FEATURES

- Controller integrated above the robot
- Intuitive web-interface
- Jerk limited trajectory generation
- Configurable workspace objects (frames, points or tools)
- Program-editor (text format IEC 61131)

## INTERFACES

- |                  |                                     |
|------------------|-------------------------------------|
| • Communication: | Ethernet, TCP/IP, HTTP              |
| • Digital I/Os:  | 5 inputs (24 V)<br>5 outputs (24 V) |
| • Power supply:  | 24 V, 4 A                           |

## OPTIONS

- Rotation-axis (Rz)
- Embedded vertical compliance module
- Vision-kit
- Tool changer

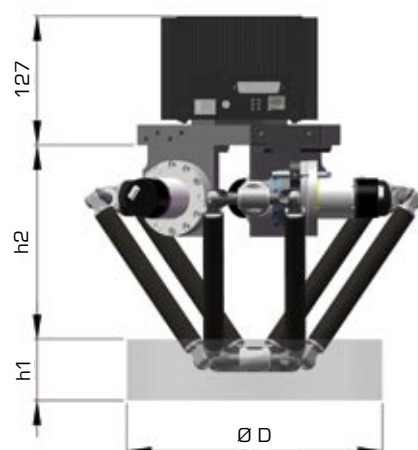
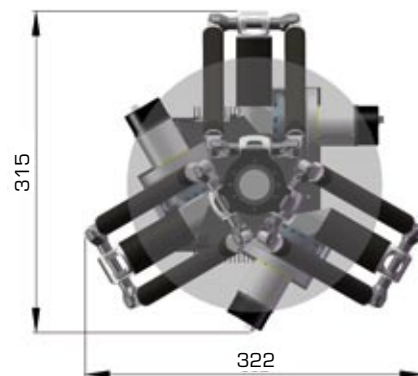

asyril sa

z.i. du vivier 16  
1690 villaz-st-pierre  
switzerland

phone +41 26 653 71 90  
fax +41 26 653 71 91  
[www.asyril.ch](http://www.asyril.ch)

**asyril** experts in  
mechatronics